

EUROPEAN COOPERATION
IN THE FIELD OF SCIENTIFIC
AND TECHNICAL RESEARCH

COST 2100 TD(07) 343
Duisburg, Germany
2007/Sept/10-12

EURO-COST

SOURCE: TSC Signal Theory and Communication Department
Castelldefels School of Technology, EPSC
UPC, Spain

Physical layer simulation platform for DVB-T and DVB-T2

S.Ruiz-Boqué, C.Enrique, C. Lopez, G.Martorell, L.Alonso, M.Garcia, F.Minerva *
Department of Signal Theory and Communications
Castelldefels School of Technology, EPSC (UPC),
Avda Canal Olímpic sn
08860 Castelldefels, SPAIN
* i2CAT Foundation, Barcelona, SPAIN

Phone: + 3493 413 70 00
Email: silvia.ruiz@upc.edu, flaminio.minerva@i2cat.net

Physical layer simulation platform for DVB-T and DVB-T2

S.Ruiz-Boqué, C.Enrique, C. Lopez, G.Martorell, L.Alonso, M.Garcia, F.Minerva *

Department of Signal Theory and Communications
Technical University of Catalonia (UPC), Barcelona, Spain
silvia.ruiz@upc.edu

* i2CAT Foundation, Barcelona, Spain, flaminio.minerva@i2cat.net

Abstract— This paper addresses the analysis of several proposals to increase capacity for the next standard of Digital Video Broadcasting. In order to evaluate the performance of the proposals, a software PHY layer simulation platform has been carried out. This tool is described herein together with some preliminary results that are shown and discussed.

I. INTRODUCTION

With the switch-off of analog terrestrial television services planned for 2009 in some countries, the DVB consortium considered appropriate the definition of an enhanced DVB-T standard, known as DVB-T2.

DVB-T standard was developed more than 10 years ago. Since then, several radio communication standards based on OFDM have been defined, employing different coders, interleavers, modulators, pilot distributions, transmission and reception diversity, MIMO's etc. offering better features than those of the DVB-T standard.

The main requirements of DVB-T2 are [1]:

- Shall be designed for stationary reception but it shall be possible to design DVB-T2 networks for all three receiving conditions, fixed, portable and mobile.
- Transmissions shall meet the interference levels and spectrum mask requirements and not cause more interference than DVB-T would do.
- Should target the maximum increase in net payload capacity over DVB-T with similar or better robustness than DVB-T under similar conditions.
- Shall provide a minimum increase in net payload capacity of 30% greater than DVB-T for any given channel profile under similar conditions. This shall be provided using existing transmitter sites and masts broadcasting to existing DVB-T domestic antenna and cable installations being backward compatible with DVB-T.
- Should offer improved robustness against interference from other transmitters, compared to DVB-T, potentially improving frequency reuse.

- Higher coverage area: 30% of increase in lateral spacing between transmitters in a Single Frequency Network (SFN).
- Shall offer a choice of various robustness and protection levels to be applied equally on all data of a transport stream carried by a DVB-T2 signal in a particular channel.
- Should offer a choice of various robustness and protection levels for each service separately, within a transport stream carried by a DVB-T2 signal in a particular channel. When more than one transport stream is carried by a DVB-T2 signal in a particular channel, the DVB-T2 specification should offer a choice of various robustness and protection levels for each transport stream separately.
- Shall provide a QoS across the whole channel that approximates to no more than one corrupted event (to any audio, video or data services) per hour for HDTV and SDTV services.
- Shall enable changes in modulation mode to be detected automatically within 0,5s. However, the receiver may not be capable of performing seamless changeover.

To achieve all these performance goals the physical layer should be redefined. Test and development methodologies are thus required to compare the different strategies proposed by researchers and institutions.

II. FURIA PROJECT

The FURIA project (Future Audiovisual Integrated Network) [2] is a Strategic and Singular Project coordinated by Abertis Telecom, oriented to form a strong Spanish consortium that will develop and validate the integration of the emerging technologies for the broadcast of media contents to fix/handheld terminals.

The consortium is composed of 25 partners being 69% of them companies and 31% technological centres and universities.

Between their technological objectives we can find: DVB-H, IPDataCast, Hybrid Terrestrial-Satellite Networks (DVB-SH) and DVB-T2 and its application to High Definition services.

FURIA deals with strategic issues of the sector as defined by eNEM (the Spanish Technological Platform for Network Audiovisual Technologies, promoted by the Spanish Industry Ministry).

The project is coordinated with other international projects and organizations (B21C) [3], via agreements or clustering, to support the leadership of European technological industry.

III. DVB-T/T2 SIMULATION PLATFORM

The simulation platform uses MatLab to facilitate a compatible environment between researchers. The blocks that have been implemented are the following:

- Transmitter: it consists of the transport multiplex adaptation and randomization, outer coding and interleaving (RS code and convolutional interleaving), inner coding (punctured convolutional code), and bit and symbol interleaving, symbol mapping, OFDM symbol transmission (2K and 8K modes are supported, with configurable guard period), raised cosinus filtering and channel performance.
- Channel: several types of channels have been included in the simulation tool:
 - o Ideal Gaussian channel
 - o ETSI model (a static multipath channel) which considers 20 multipath components with constant amplitude, phase and delay.
 - o Rician channel (F1) where a predominant LOS path is included with a power level 10 dB higher than the rest of paths (K=10)
 - o Rayleigh channel (P1) where the direct path is removed (NLOS).

- o Finally, the TU-6 model has been also implemented but considering only small Doppler frequencies (below 10 Hz).

- Receiver: It consists of a replica of the transmitter blocks. Regarding the inner decoding, a quasi-optimum soft Viterbi decoder is implemented. Furthermore, several channel estimation techniques have been considered:
 - o ideal (for each subcarrier),
 - o ideal estimation for the pilot subcarriers and then a linear interpolation for data subcarriers is performed.
 - o real estimation for pilot subcarriers (considering the degradation due to noise) and then the linear interpolation for the data subcarriers is performed.

The block diagram of the simulator is represented in Figure 1 while in Tables 1 and 2 the main configuration parameters are listed.

The system is able to calculate the BER and capacity for different modulations, coding rates (puncturing values), symbol mapping, system modes (2k and 8k OFDM modes), guard periods, channel models, channel estimation techniques, etc.

Parameter	8K mode	2K mode
Number of sub-carriers, N	8192	2048
N. of useful sub-carriers Nu	6817	1705
N. of data sub-carriers Nd	6048	1512
N. of pilot sub-carriers Np	769	193
Elementary frequency 1/T	64/7(MHz)	64/7(MHz)
Useful Duration Tu	NxT=896 μs	NxT=224 μs
Sub-Carrier Spacing 1/Tu	1116 Hz	4464 Hz
Bandwidth (MHz)	Nu/Tu=7.61	Nu/Tu=7.61

Table 1: Carrier/Subcarrier specification

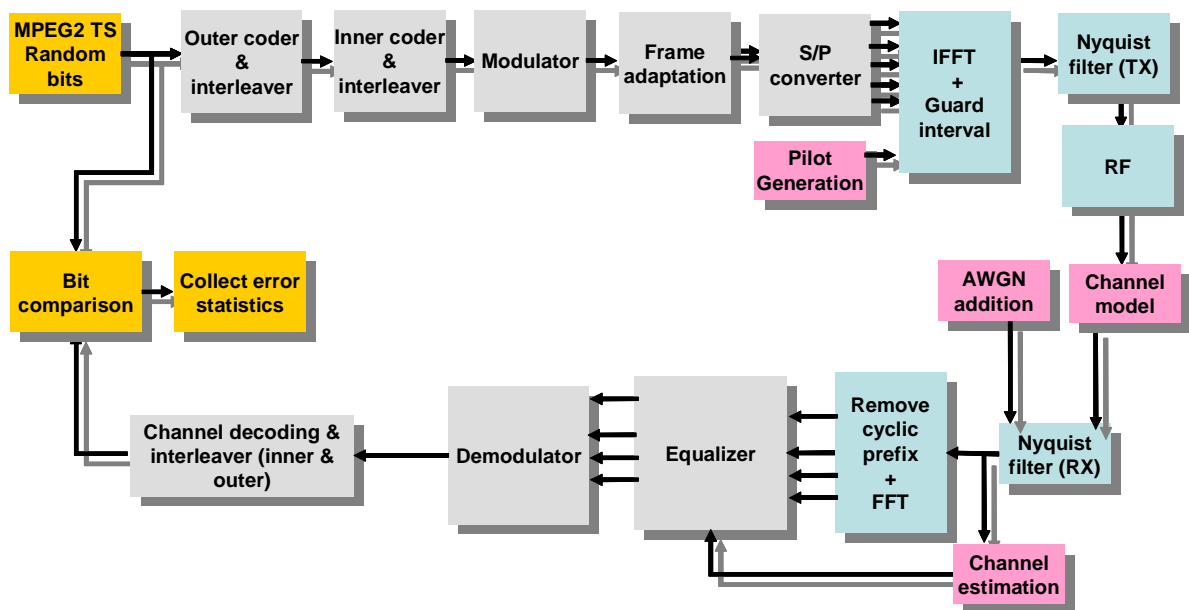

Figure 1: block diagram of DVB system

The raw bit data rate is calculated as: $f_r = f_s (\text{symbol} / \text{s}) \cdot v (\text{bit} / \text{symbol}) \cdot N_d$ being v the number of bits per symbol (2 when using QPSK, and 4 and for 16QAM, 6 for 64QAM and so on). The net bit rate is obtained by $f_{net} = f_r \cdot r \cdot RS$ being r the convolutional code rate and RS the Reed Solomon code rate (188/204) [4].

Mode	8K mode				2K mode			
GI Δ /Tu	1/4	1/8	1/16	1/32	1/4	1/8	1/16	1/32
Δ (μ s)	224	112	56	28	56	28	14	7
Ts	1120	1008	952	924	280	252	238	231
fs, baud	892	992	1050	1082	3571	3968	4201	4329

Table 2: Effect of the guard interval on symbol parameters

IV. DVB-T2: PROPOSED IMPROVEMENTS

Identifying possible feasible improvements and testing them with the developed simulator is the main research task to be performed. It should be considered that DVB organization has just opened the Call For Technologies few months ago, so everything is still open in this area. We have chosen the following issues to be studied (although the study is not closed and new proposals can be included while others can be discarded):

- New Modulation Schemes, using higher order constellations (for example 256 and 512-QAM).
- New encoding algorithms for error protection
- New pilot pattern for channel estimation and synchronization.

- New techniques for spectrum shaping and intercarrier interference reduction.
- Higher number of subcarriers, with 16K, 32K modes
- Inclusion of MIMO techniques.

Changing the modulation to 256 or 512 QAM allows higher bit rate but also requires higher E_b/N_0 , so this may be only feasible if more efficient codes are used.

In figure 2 the maximum achieved spectral efficiency is represented as function of the E_b/N_0 for different modulations and system parameters. In the simulations QEF (quasi error free) condition has been considered, which corresponds to having the BER (Bit Error Rate) after the Viterbi decoder equal to 10^{-4} , obtaining a BER of 10^{-11} after the Reed Solomon decoder.

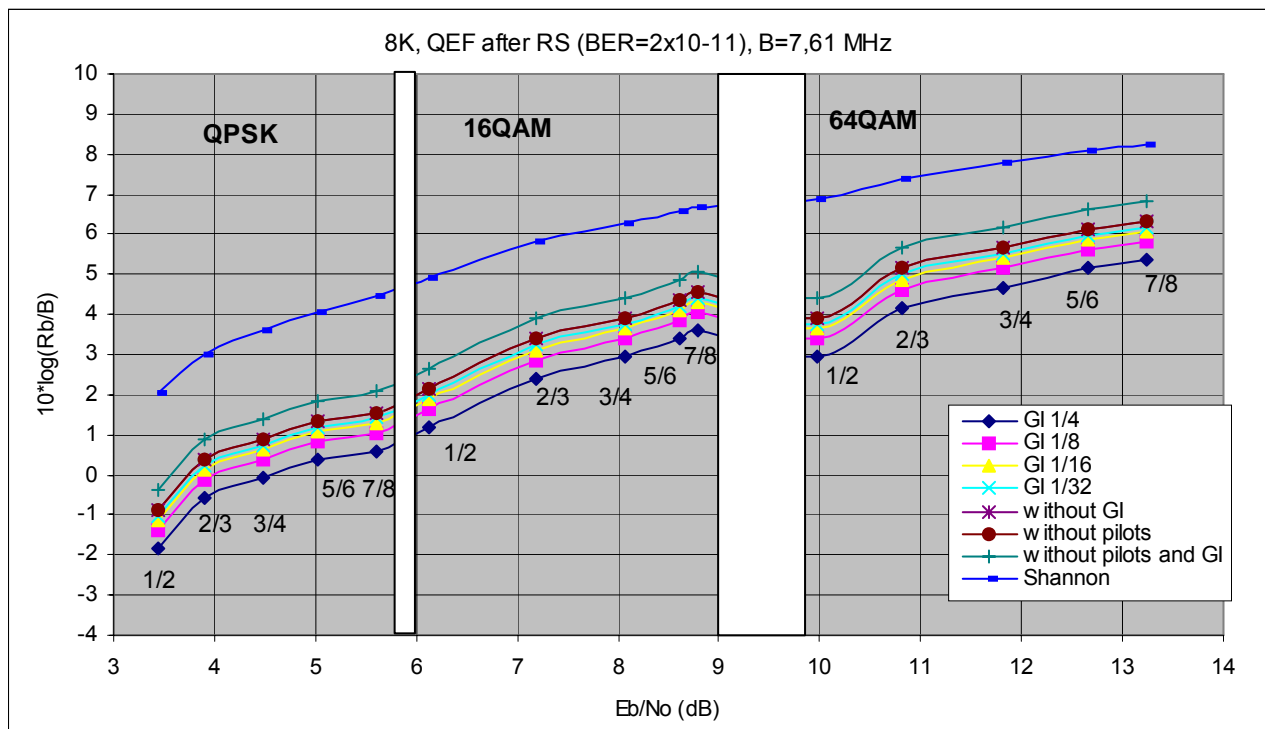

Figure 2: Spectral efficiency for QEF DVB-T system

The channel bandwidth is $B=7.61$ MHz, calculated as the product of the subcarrier separation 1,116 KHz by the number of useful subcarriers 6817 (for 8K mode). Results for QPSK, 16QAM and 64QAM are given for all the combination of convolutional code rate r (1/2, 2/3, 3/4, 5/6 and 7/8), and for the different values of guard interval considered by the DVB-T standard (1/4, 1/8, 1/16 and 1/32).

The maximum spectral efficiency is calculated as the quotient between the data bit rate R_b (net rate) and the channel bandwidth B , and it is represented as function of the data E_b/N_0 . The carrier to noise ratio is calculated as

$$\frac{C}{N} = \frac{E_b}{N_0} \cdot r \cdot \frac{188}{204} \cdot \log_2 M = \frac{E_b}{N_0} \cdot \frac{R_b}{B}$$

being M the

number of symbols of the constellation.

It can be appreciated that the differences between having a Guard Interval of 1/8, 1/16 and 1/32 are small, being 1/8 the most robust against intercarrier interference.

There is now an open discussion about the effects of removing the GI and the pilot structure, studying alternatives to system synchronization, channel estimation and interference reduction. Therefore, we have included these aspects in the simulation tool, in order to test which is the capacity increase, but assuming ideal synchronization, channel estimation, etc. (that is, without proposing any alternative of how to do it).

This fact is also represented in figure 2. We can observe that for $GI=1/4$ the capacity increase is around 25%, while it gets lower as the GI is reduced (12,5% for $GI=1/8$, 6,25% for $GI=1/16$ and 3% for $GI=1/32$). Assuming that $GI=1/8$ is a good compromise between capacity and interference reduction, the capacity gain obtained when eliminating the GI is around 12.5% (this is the one represented in Fig.2).

We can also consider the spectral efficiency increase obtained when eliminating the pilots. We have considered that all the pilots are removed (scattered SP, continuous CP, and TPS). In this case the gain is around 12.7%.

Finally, and considering both effects together, an asymptotic capacity increase is achieved between 40% (compared to $GI=1/4$) and 16% (compared to $GI=1/32$). In Figure 2 we have considered a joint capacity increase of 26% (compared to $GI=1/8$).

Translating the E_b/N_0 values of figure 2 to C/N values, by using a previously presented expression, the maximum C/N required values are around 20 dB.

In figure 3, the same parameters have been represented considering only a 256QAM modulation. In this case up to 25 dB of C/N are required.

It should be noted that changing the modulation level also implies changes within the bit-wise interleaver structure, in order to be able to adapt up to 9 parallel bit interleaver structures.

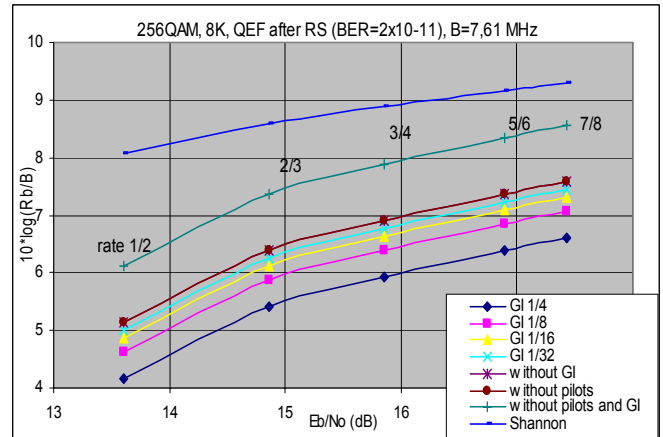

Figure 3: Spectral efficiency versus Power efficiency for QEF using 256QAM.

It has been considered to be also interesting to represent in both, figures 2 and 3, the Shannon capacity limit for the channel, in order to see how close the different assumptions considered are to it. Recall that the Shannon limit states that

$$2 \frac{R_b}{B} \leq 1 + \frac{E_b}{N_0} \cdot \frac{R_b}{B}$$

It seems necessary the use of powerful codes, the ones recently defined for DVB-S2 [5] have been proposed to be included in DVB-T2: BCH as outer code instead of Reed Solomon, and LDPC as inner code instead of a regular convolutional one. These codes are also the ones adopted by the Chinese DVB standard, DTMB [6]. These codes are not yet implemented in the simulator but it seems clear the effect they will produce will be a reduction in the required C/N or E_b/N_0 to achieve a given BER, while maintaining the spectral efficiency and therefore the capacity in terms of effective Mbps. This could be modelled by simply shifting to the left the previous lines, with a shift equal to the coding gain. As a consequence, and keeping constant the E_b/N_0 value, a higher spectral efficiency (and therefore higher capacity) is achieved.

The requirement of offering a higher coverage area, with a 30% of increase in spacing between transmitters, means that the new standard must be able to cope with higher multipath delays. This could be accomplished by increasing the number of OFDM subcarriers. As an example, the available maximum tolerable delays for different situations are given in table 3. It is assumed that the number of pilot subcarriers is up to 11,32% of the useful subcarriers as in modes 2K and 8K. The rest of parameters are:

- 16K: $N=16384$, $T_u=1792 \mu s$, $N_u=13637$, $N_p=1543$
- 32K: $N=32768$, $T_u=3584 \mu s$, $N_u=27274$, $N_p=3087$.

	8k		16K		32K	
Δ/T_u	μsec	Km	μsec	Km	μsec	Km
1/4	224	67,2	448	134,4	896	268,8
1/8	112	33,6	224	67,2	448	134,4
1/16	56	16,8	112	33,6	224	67,2
1/32	28	8,4	56	16,8	112	33,6

Table 3: guard interval and maximum allowed delay

The new pilot pattern could be based on the transmission of known sequences with a given periodicity at OFDM symbol level (lower than the pilot subcarriers structure used now).

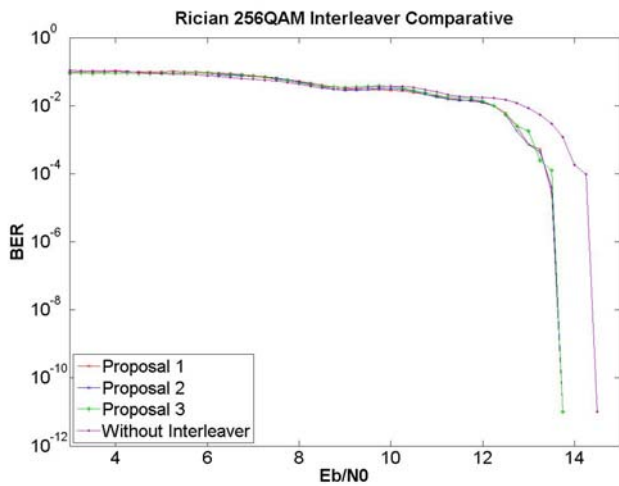

Figure 4: BER for 256QAM and Rician channel for different interleaving structures.

In figure 4, the effect of different interleaving structures aimed to adapt the DVB-T system to be able to use 256QAM is tested for the Rician multipath channel (F11 defined by ETSI). As observed, the three proposals under test have similar performance. In this figure the BER when no interleaving is introduced is also represented. It can be appreciated that the interleaver allows a reduction of around 1 dB in terms of required Eb/No.

In figure 5 the BER for 64Q AM with $GI=1/4$ and different code rates is represented when considering the F11 channel model.

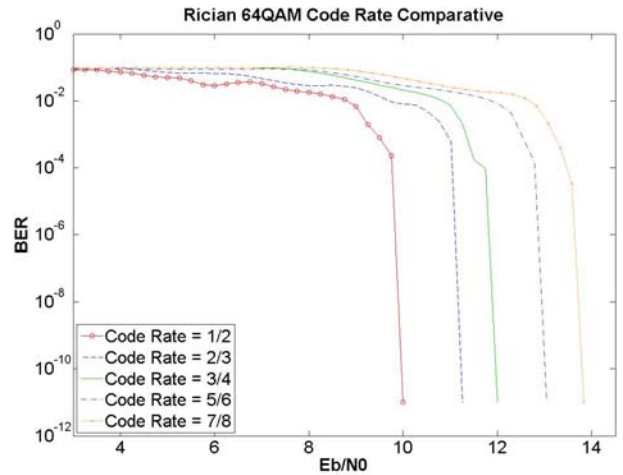

Figure 5: BER for 64QAM and different code rates ($GI=1/4$)

In figure 6 the comparison between the Eb/No values required to maintain a certain level of BER are represented for the two channels modeled in this study: Gaussian and F11. It can be observed that with the static Rician multipath channel there is a low degradation of around 1 dB. Worse values are expected when considering the reduced mobility scenario with Rayleigh multipath components and Doppler frequency between 3-10 Hz.

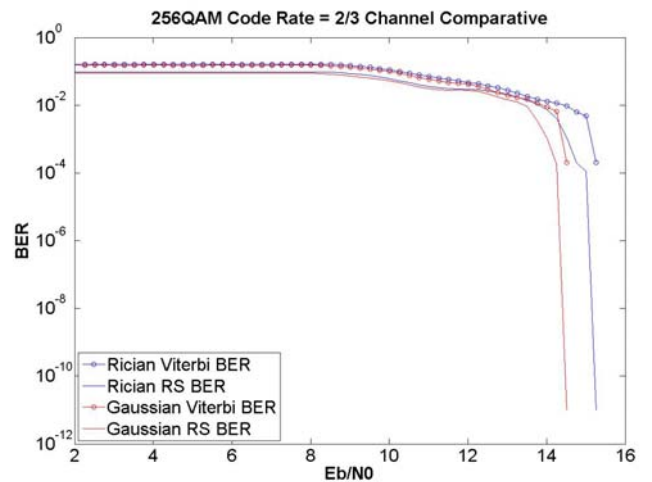

Figure 6: BER for 64QAM and different code rates ($GI=1/4$)

Finally, figures 7 and 8 give a comparative analysis between using an ideal channel estimator and a semi ideal one. Ideal estimation means that the channel for each subcarrier is perfectly known, while the semi-ideal one means that the pilots are estimated perfectly, and after that an interpolation to obtain channel parameters for the data subcarriers between pilots is applied. It can be appreciated that a degradation of around 2 dB in Eb/No is suffered. Results considering imperfect channel estimation for the pilots are not within the scope of this work, so this situation is left for future analysis.

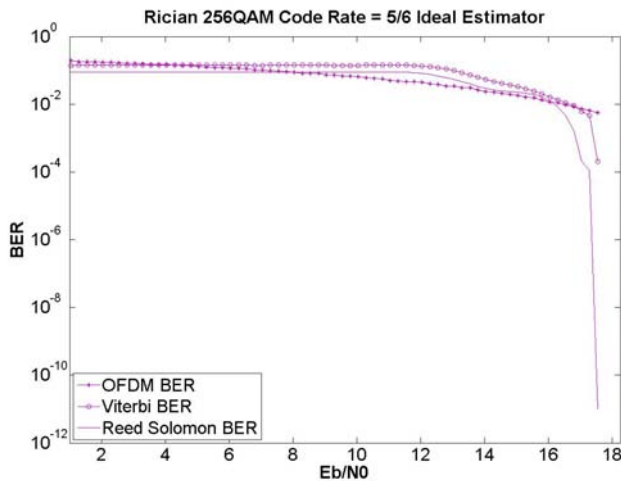

Figure 7: BER for 256QAM and ideal channel estimation for Rician channel

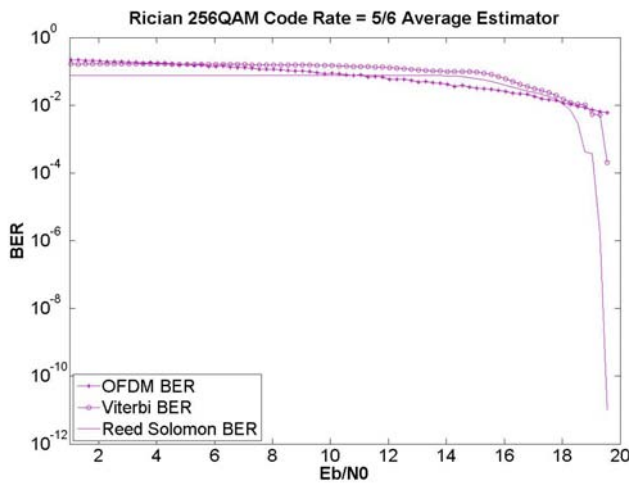

Figure 8: BER for 256 QAM and Rician channel with semi-ideal channel estimation.

V. CONCLUSIONS AND FUTURE WORK

In this paper some considerations about the next standard of terrestrial DVB-T2 have been presented. A simulation platform has been described together with some ideas of how increase the capacity of the system. Results for Gaussian and static multipath channels have been presented. In future work, the objectives are to reproduce the same analysis considering portability and also reduced mobility for low Doppler values defining the most appropriate channel models to do so. Work is also in process to introduce BCH+LDPC codes in the simulator, as well as transmission/reception diversity as a previous step for introducing MIMO structures later on.

Acknowledgment: This work has been supported by i2CAT Foundation (www.i2cat.cat) through the joint collaboration at FURIA project (Spanish Ministry of Industry, FIT-330503-2006-6. It has been also funded by the Spanish Research Council CICYT+FEDER through the projects TEC2005-07326-C02-01/TCM and TEC2006-09109.

REFERENCES

- [1] DVB organization <http://www.dvb.org/technology/>
- [2] FURIA spanish project : Future Audiovisual Networks <http://www.furiapse.com/ingles/index.htm>
- [3] Celtic project B21C: Broadcast for the 21st century <http://www.celtic-initiative.org/Projects/B21C/abstract.asp>
- [4] Digital Video Broadcasting (DVB); Framing structure, channel coding and modulation for digital terrestrial television. ETSI EN 300 744
- [5] DVB-S2 EN 302 307 published by ETSI
- [6] Jiang Song. Technical Review of the Chinese Digital Terrestrial Television Broadcasting Standard (DTMB). December, 2006.